

VMP - Vertical Multiport Boiler

Efficient • Reliable • Compact

40BHP - 150BHP*

Fulton's VMP Steam Boilers feature a small footprint, overall even heating, and high efficiencies.

Key Design Features

- Heavy walled Schedule 80 flue pipes - no tubes to replace.
- Ribboned turbulators for maximum efficiency.
- Insulation blanket surrounding the boiler results in lower outside jacket temperature.
- Small footprint - compact design.
- Built/certified to ASME and other applicable codes.
- Entire boiler is UL listed.



*Consult factory for availability of 150BHP.



"Ribboned" Turbulators

These turbulators extend the full length inside each flue pipe and maximize the overall heat transfer. They can be removed quickly and easily for cleaning and maintenance of the flue pipes by unbolting the top plates on the boiler.

Look Inside

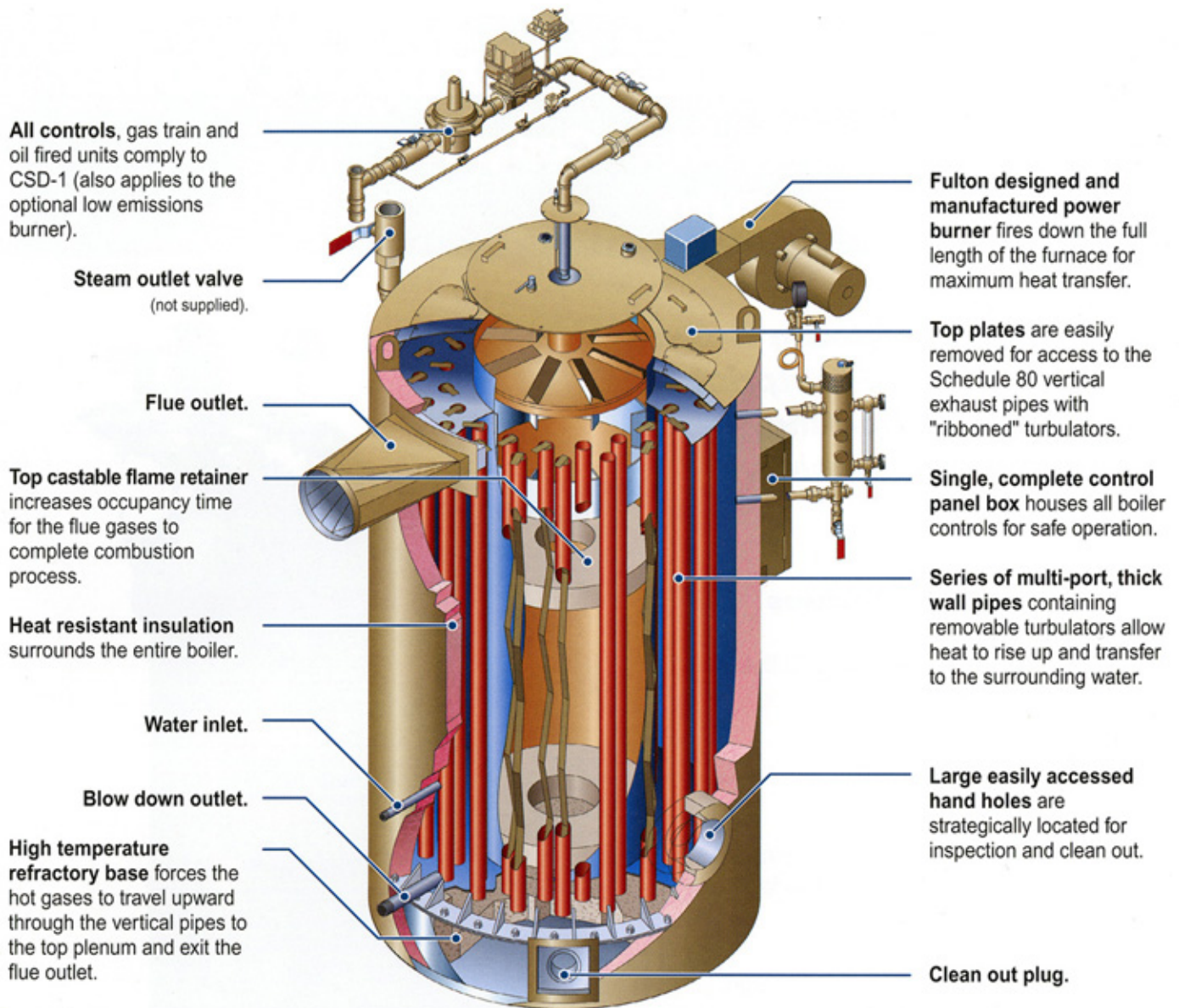

The Fulton Difference

Pipe vs. Tube

Fifty years after creating the vertical tubeless category of boilers, Fulton has introduced another innovation - the PipeType Boiler. Constructed of Schedule 80, heavy wall pipes, tube replacement is a thing of the past. This simple design is proven by decades of experience, and is backed by our unmatched warranty.



Product Data Submittal

Fulton Models: VMP40, VMP49.5, VMP50, VMP60, VMP80, VMP100, VMP130 and VMP150

Fulton Vertical MultiPort Steam Boilers (Standard Burners)

Dimensions

Models VMP		40	49.5	50	60	80	100	130	150
Unit Size:	BHP	40	49.5	50	60	80	100	130	150
A. Boiler Diameter	IN	49	55	55	55	63	69	76.5	76.5
	MM	1245	1397	1397	1397	1600	1753	1943	1943
B. Boiler Height	IN	84	91	91	97	100	100	115	115
	MM	2133	2312	2312	2464	2540	2540	2921	2921
C. Boiler Depth	IN	90	100	100	100	114	119	128	130
	MM	2286	2540	2540	2540	2896	3022	3251	3302
D. Boiler Height w/trim	IN	107	112	112	118	124	126	135	141
	MM	2718	2832	2832	2984	3150	3200	3429	3582
E. Overall Boiler Width	IN	56	62	62	62	68	74	84.5	84.5
	MM	1422	1575	1575	1575	1727	1880	2146	2146
F. Flue Outlet Diameter	IN	12	12	12	12	14	14	14	16
	MM	305	305	305	305	356	356	356	407
G. To Center of Flue Outlet	IN	79	86	86	92	95	95	107	107
	MM	2006	2184	2184	2237	2413	2413	2718	2718
H. Feedwater Inlet	IN	35	35	35	35	35	35	39	39
	MM	889	889	889	889	889	889	991	991
J. Blowdown Outlet	IN	17	18	18	18	18	18	22	22
	MM	432	457	457	457	457	457	559	559
K. Height to Steam Outlet	IN	73	77	77	84	89	89	102	102
	MM	1854	4956	4956	2134	2260	2260	2591	2591
L. Min. Clearance to Ceiling	IN	110	115	115	125	130	132	145	145
	MM	2794	2921	2921	3175	3302	3353	3683	3683

Specifications and Dimensions are approximate. We reserve the right to change specifications and/or dimensions.

NOTE: Minimum clearance is 24" to the side and back and 36" in front of unit.

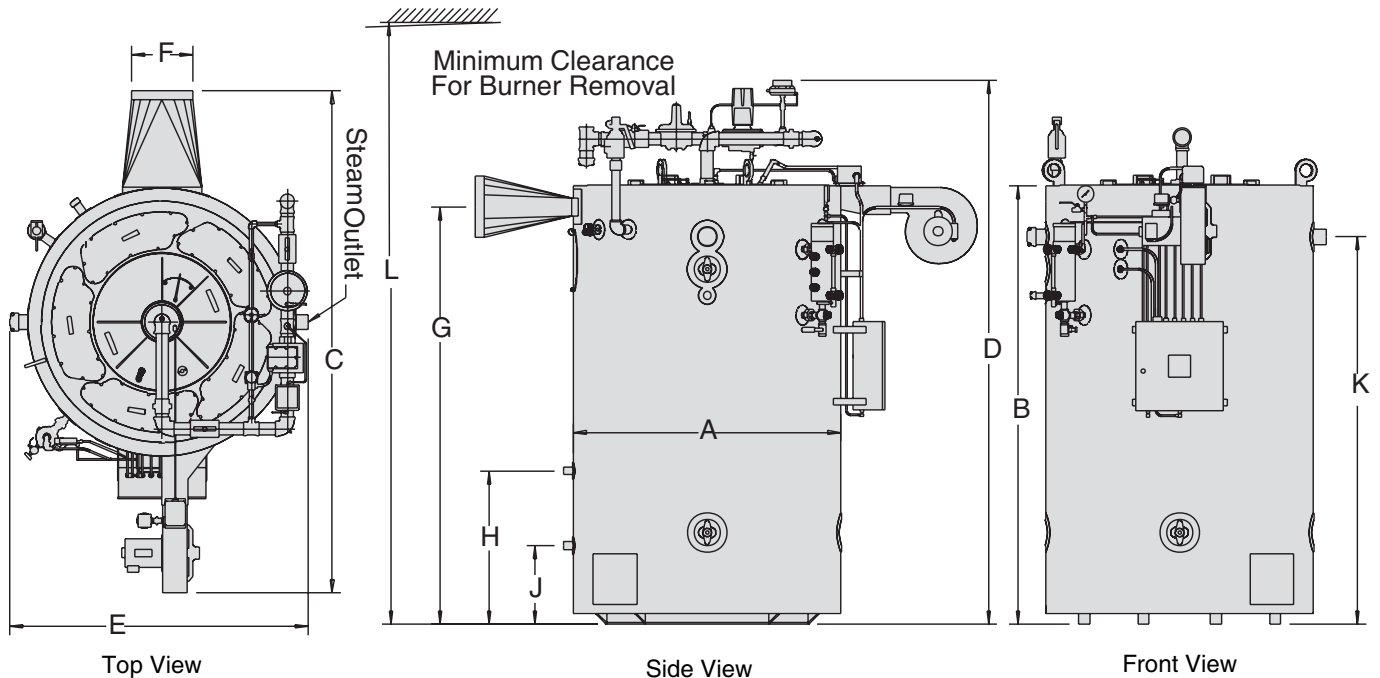

Specifications

972 Centerville Road
 Pulaski, New York USA 13142
 Call 315-298-5121
 Fax 315-298-6390
 web site: www.fulton.com

Fulton Thermal Corporation

Models VMP		40	49.5	50	60	80	100	130	150
Unit Horsepower		40	49.5	50	60	80	100	130	150
Boiler Connections									
Steam Outlet 15 PSI - 150# Flanged	IN	4	4	4	4	6	6	* 6	* 6
	MM	101	101	101	101	152	152	203	203
Steam Outlet 150 PSI	IN NPT	3	3	3	3	3	3	4	4
	MM	76	76	76	76	76	76	101	
Feedwater Inlet	IN NPT	1	1	1	1	1	1.25	1.25	1.25
	MM	25	25	25	25	25	31	32	32
Blowdown Outlet (2)	IN NPT	1.5	1.5	1.5	1.5	1.5	2	2	2
	MM	38	38	38	38	38	51	51	51
Water Column Blowdown	IN NPT	1	1	1	1	1	1	1	1
	MM	25	25	25	25	25	25	25	25
Surface Blowdown	IN NPT	.75	.75	.75	.75	.75	.75	.75	.75
	MM	19	19	19	19	19	19	19	19
Safety Valve 150 PSI Inlet	IN NPT	.75	1	1	1	1.25	1.25	1.5	1.5
	MM	19	25	25	25	31	31	38	38
Safety Valve 150 PSI Outlet	IN NPT	1	1.25	1.25	1.25	1.5	1.5	2	2
	MM	25	31	31	31	38	38	51	51
Safety Valve 15 PSI Inlet (2)@	IN NPT	1.25	1.25	1.25	1.25	1.5	1.5	2	2
	MM	31	31	31	31	38	38	51	51
Safety Valve 15 PSI Outlet	IN NPT	1.5	1.5	1.5	1.5	2	2	2	2
	MM	38	38	38	38	51	51	51	51
Natural Gas Connection	IN	1.5	1.5	1.5	2	2	2	2	2
	MM	38	38	38	51	51	51	51	51
Light Oil Connection	IN	.25	.25	.25	.25	.25	.25	.375	.375
	MM	6	6	6	6	6	6	9.5	9.5
Burner Motor (Gas)	HP	1.5	1.5	1.5	1.5	3	3	10	10
	KW	1.1	1.1	1.1	1.1	2.2	2.2	7.5	7.5
Burner Motor (Oil/Combo)	HP	2	2	2	2	3	3	10	10
	KW	1.5	1.5	1.5	1.5	2.2	2.2	7.5	7.5
Approximate Weights									
Shipping Weights (approx.)	LB	5775	6550	6575	7370	8000	9500	12350	12350
	KG	2620	2972	2980	3340	3630	4310	5600	5600
Operating Weight (approx.)	LB	6720	8850	8209	9227	11760	14525	20135	20135
	KG	3050	4015	3720	4190	5330	6590	9130	9130
**Ratings Sea Level to 3000 FT. (914 M)									
Output	1000 BTU/HR	1339	1657	1674	2009	2678	3348	4352	5021
	1000 KCAL/HR	337	418	422	506	675	844	1100	1270
Steam Output	LBS/HR	1380	1707	1725	2070	2760	3450	4485	5175
	KG/HR	626	775	783	939	1252	1565	2035	2348
Water Content	GAL	172	274	242	270	383	518	810	810
	LITERS	651	1038	916	1022	1450	1960	3066	3066
Approximate Fuel Consumption at Rated Capacity+									
Natural Gas	FT ³ /HR	1595	1972	1992	2392	3188	3985	5200	5978
	M ³ /HR	45	56	56	68	90	113	147	169
LP Gas	FT ³ /HR	638	788	797	957	1275	1594	2080	2391
	M ³ /HR	18	22	23	27	36	45	59	68
Light Oil	GPH	11.4	14.1	14.2	17.1	22.8	28.5	37.1	42.7
	LPH	43.1	53.3	53.9	64.7	86.2	107.7	140.6	161.6
Gas Pressure Required Standard Burners Min.	IN W.C.	7	7	7	7	9	9	40	40
Gas Pressure Required Standard Gas Train Max.	IN W.C.	13	13	13	13	27	27	5 psig	5 psig
Electrical Requirements/Amps for Burner Motors									
208V, 50/60 CY, 3 Phase (Gas/Oil)		6.6/7.5	6.6/7.5	6.6/7.5	6.6/7.5	10.6	10.6	30.8	30.8
230V, 50/60 CY, 3 Phase (Gas/Oil)		6.0/6.8	6.0/6.8	6.0/6.8	6.0/6.8	9.6	9.6	28	28
460V, 50/60 CY, 3 Phase (Gas/Oil)		3.0/3.4	3.0/3.4	3.0/3.4	3.0/3.4	4.8	4.8	14	14

* Steam separator or dual steam nozzle design required.

**Ratings - From 0 PSIG and at 212 Degrees F and KG/HR - From 0 KG/CM² and at 100 Degrees C +Consumption based on natural gas 1000 BTU/FT³; Propane 2500, and Light Oil 140,000 BTU/GAL.

NOTE: 7" - 11" wc gas pressure is required during run for 40-60 HP boilers with standard burners. 9"-11" wc gas pressure is required during run for 80-100 HP boilers with standard CSD-1 burners. 40" W.C. is required for 130-150 HP

Specifications & dimensions are approximate. We reserve the right to change without notice.